

Removing the curl

This print has been rolled rather than flat-packed for the purpose of easy transit and to ensure it is received by you, the purchaser, in a secure and undamaged state.

Inevitably, after you have carefully unpacked the print, you will find it will initially retain much of the curl that has resulted from being sent rolled up in a tube.

You are advised not to try and uncurl the print by rolling it the opposite way as this may cause damage. This is a specialist job and a framer's workshop is the best place to get this done properly. They often have a gadget which is specially made for the purpose or are used to doing this all the time.

I would strongly advise that you have the print professionally framed to help in ensuring it lasts as long as possible. You should ask for conservation quality mountboards and backing boards to be used.

If you decide that you are going to frame the print yourself, then you could place the print with the image side face-down between two sheets of clean, flat and dust-free mounting board with a pile of books on top. This should take out most of the curve after several days. Do this very carefully!

Make sure you do not accidentally turn or bend the corners of the print over as you are placing the board on top as this will result in folds or creases and in the event of a return, a full refund will not be made for any item which has been damaged by the customer.

Do not use newspaper or other printed materials to interleave the boards; as ink may transfer to the print under pressure. Do not use boards which have an embossed pattern such as corrugated card as this may mark the print.

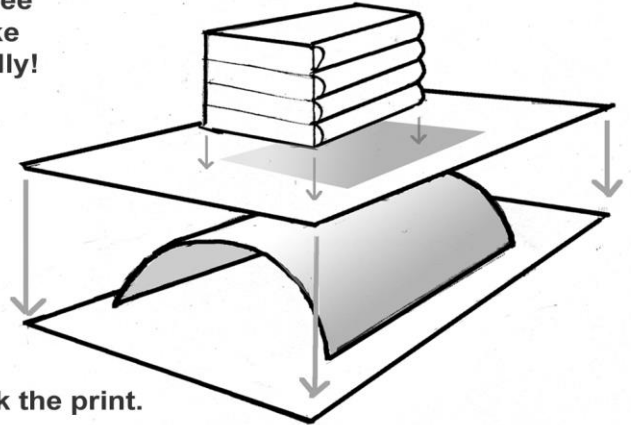

Leaving the print between the boards for several days should eliminate most of the curvature.

If you are having the print framed by a professional framer, keep it rolled up in transit to the framer's workshop and they will be able to deal with getting it back into a flat state. My advice would be keep it out of the tube once you have taken it out!

However, if you do decide to try and re-roll the print and put it back, great care should be taken in order to avoid possible damage. My advice would be don't try and push it back into the tube. If it won't go in easily do not force it!

Once most of the curve is out, the act of putting it in a frame with backing board and a mount will ensure the print flattens out completely.

Please do not touch/damage the print surface !

This print is produced using the finest materials but the matt image surface is prone to being easily marked.

Therefore, please do not touch or rub the image side of the print however lightly with fingers or with anything else. This will lead to finger marks and scratches being left on the ink surface which are permanent and cannot be removed.

All prints are sent in pristine condition and full refunds will not be made for items where damage has evidently been made to the print surface by the customer - howsoever caused.



Correct display of print & risk from Sunlight & other strong light

It is strongly advised that prints are not displayed in direct sunlight as this could lead to fading of the image due to UV light. Choose a wall which does not receive the sun all day every day or where there isn't lots of strong sunlight bouncing about or constant strong artificial light.